

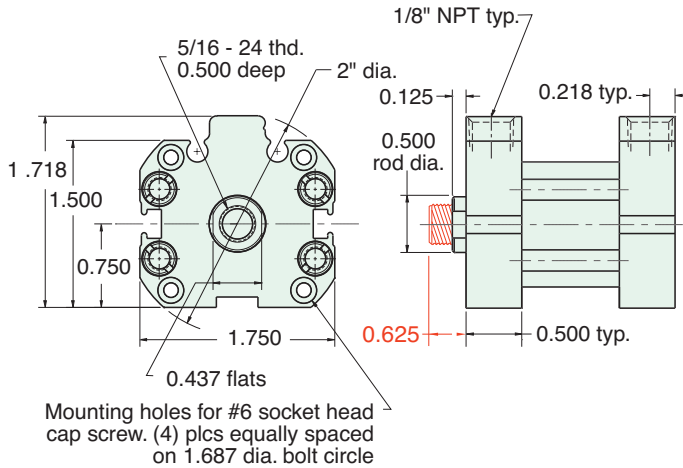

1 1/16" BORE AFO COMPACT CYLINDER

AF - □□□ - 17 - □



For rod with male thread option, add -T to the end of the part number after Stroke
 See [page 71](#) for Air Force One numbering system

MOUNTING STYLES

Five mounting styles give you versatility and fast, easy installation.

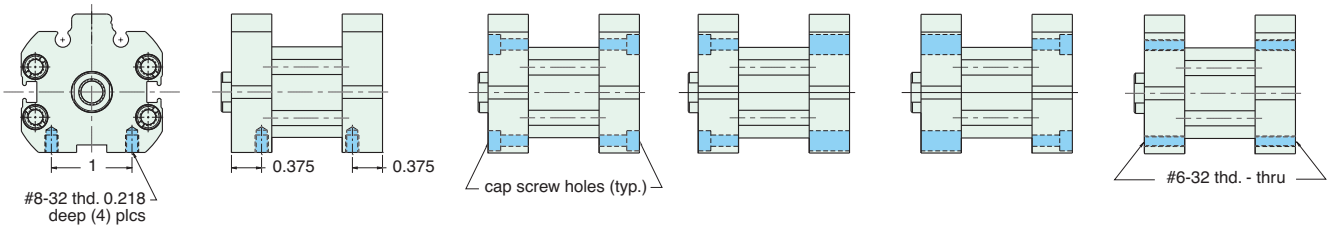

Bottom Mount
AF-Bxx-17-x

Universal Mount
AF-Uxx-17-x

Front Mount
AF-Fxx-17-x

Rear Mount
AF-Rxx-17-x

Thread Mount
AF-Txx-17-x

CYLINDER LENGTHS

"L"	Stroke	Spring Return	Spring Extend
L1	1/4" - 1"	7/8"	
L1	1 1/8" - 2"	1 1/2"	
L1	2 1/8" - 3"	2 1/8"	
L1	3 1/8" - 4"	2 3/4"	
L2	1/4" - 1"		1 3/8"
L2	1 1/8" - 2"		2"
L2	2 1/8" - 3"		2 5/8"
L2	3 1/8" - 4"		3 1/4"

Overall length of body is stroke plus "L"
 Add 7/8" for Magnetic Piston

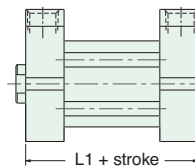

Spring Return
AF-xSR-17-x

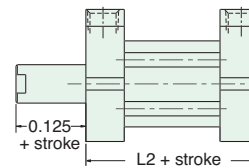

Spring Extend
AF-xRR-17-x

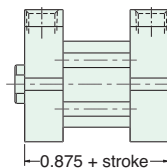

Double Acting Single Rod
AF-xDR-17-x

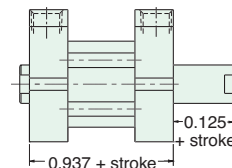

Double Acting Double Rod
AF-xDD-17-x

Spring Forces	
Spring Return	
Compressed	At Rest
11.5 lbs.	5.5 lbs.
Spring Extend	
Compressed	At Rest
11.5 lbs.	5.5 lbs.